



INSTRUCTION MANUAL

ALM

Analog Linearizing
Module

Form 158-706-00

January 1982

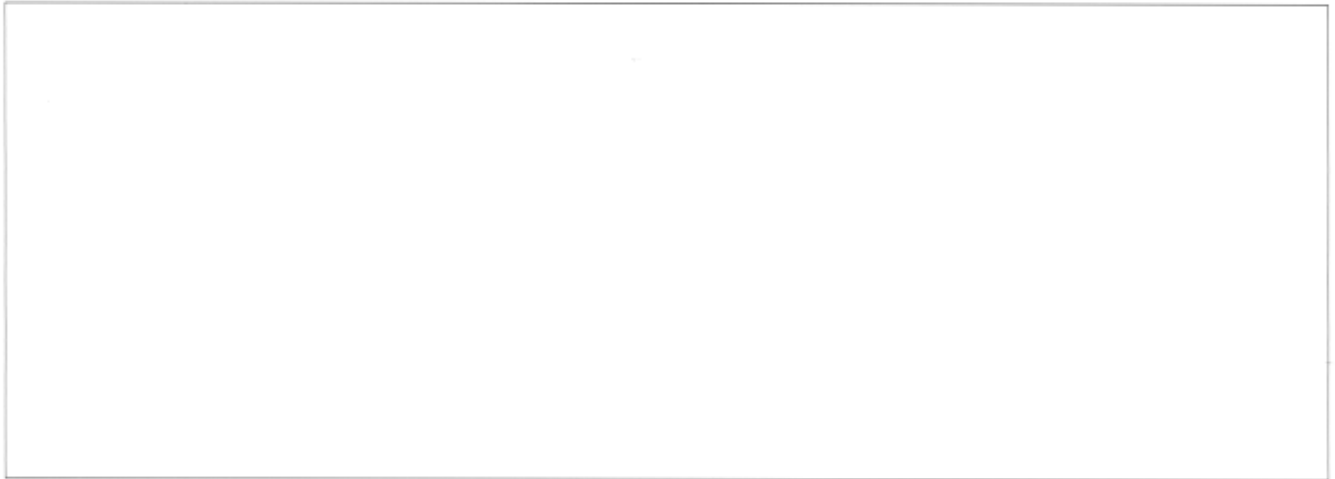

1.1 SCOPE OF MANUAL

This manual contains all necessary information for the operation, installation and maintenance of the Analog Linearizing Module (ALM). It is comprised of five sections: Introduction, Installation Information, Operating Information, Theory of Operation and Maintenance Information, including schematics, assembly drawings and parts list.

1.2 PURPOSE OF EQUIPMENT

The Analog Linearizing Module converts any monotonic curve with a characteristic of $X = Y^{1/5}$ to Y^5 into a linear function. It also converts any linear function into a monotonic curve with a characteristic of $X = Y^{1/5}$ to Y^5 . The RO option gives output curves that are the inverse of the input signal.

1.3 GENERAL DESCRIPTION

The input signal is applied to an operational amplifier where input span and zero are adjusted prior to the signal being converted to the desired linear function or monotonic curve by the function generation circuit. The resulting shaped signal is applied to an output circuit where the final output zero and span are adjusted prior to power amplification.

1.4 PHYSICAL DESCRIPTION

The ALM is available in several different physical configurations. Generally the unit has three printed circuit boards: one is the main circuit board and one board contains the power supply regulator and one contains the function generation circuit. If specified at time of order, a mounting bracket can be supplied. For hazardous environments, an explosion-proof housing with a base containing up to four threaded hubs for wiring is available. Also available are enclosures that are oil-tight, dust-tight, and water-tight. Although the printed circuit boards are identical regardless of the physical configuration and mounting method, the external electrical connections may be connected to different terminals on the terminal block or PC receptacle in the various versions of the unit. Specific details for making electrical connections are given in Section 2.

1.5 SPECIFICATIONS

The specifications of the ALM are given in Table 1-1.

TABLE 1-1. ALM SPECIFICATIONS

INPUT

<u>CURRENT</u>	1-5 mA into 1000 ohms 4-20 mA into 250 ohms 10-50 mA into 100 ohms
<u>VOLTAGE</u>	0-5, 1-5 VDC standard 1 megohm minimum input impedance Other voltages optional

FRONT PANEL ADJUSTMENTS

<u>INPUT ZERO</u>	Normalize Input Level $\pm 10\%$ of F.S.
<u>INPUT SPAN</u>	Normalize Input Level $\pm 20\%$ of F.S.
<u>FUNCTION AMPLITUDE</u>	See Function Ranges Below
<u>FUNCTION CHARACTER (N)</u>	See Function Ranges Below
<u>OUTPUT ZERO</u>	With Minimum Input, Adjusts The Output 0% $\pm 10\%$
<u>OUTPUT SPAN</u>	With Full Scale Input, Adjusts The Output To 100% $\pm 20\%$

OUTPUT

	Operational amplifier feedback current source. Output limited to 150% of maximum output range
<u>CURRENT</u>	1-5 mA into 0-6000 ohms 4-20 mA into 0-1500 ohms 10-50 mA into 0-600 ohms
<u>VOLTAGE</u>	1-5 VDC standard @ 20 mA maximum
<u>RIPPLE</u>	10 mV P/P @ maximum span and maximum load
<u>LOAD EFFECT</u>	$\pm .01\%$ of span from 0 to maximum load (current output)
<u>FUNCTION</u>	$X (\text{output}) = Y (\text{input})^N$
	where: Range A: N = 1 to 3 Range B: N = 3 to 5 Range C: N = 1 to 1/3 Range D: N = 1/3 to 1/5

TABLE 1-1. ALM SPECIFICATIONS (Cont'd)

PERFORMANCE

<u>CALIBRATION CAPABILITY</u>	±0.25% of full scale from 1% to 100% span
<u>AMBIENT TEMPERATURE RANGE</u>	0°C to +70°C, 32°F to 158°F
<u>AMBIENT TEMPERATURE EFFECT</u>	.02%/°F maximum
<u>FREQUENCY RESPONSE</u>	3 dB down at 50 Hz
<u>ISOLATION</u>	Voltage output units have input negative side common to output negative side. Current output models have output negative side elevated above input negative side (true current source). Mixed outputs are optionally available. Power input isolation is maintained on both AC and DC powered units.

POWER INPUT

24, 45, 65 VDC ±10% standard
 117, 240 VAC 50/60 Hz ±10% optional
 Line voltage effect ±0.01%/1% line change

ALM - ANALOG Linearizing Module #158-706-00

1.6 MODEL NUMBERING SYSTEM

The model number describes the instrument type, functional range and other features. Shown below is an example of the numbering system.

BASIC EXAMPLE:

ALM/1-5V/4-20MA/A/AC

ALM, 1-5V input curve, N = 1-3,
4-20 mA output, 117 VAC power.

BASIC INSTRUMENT TYPE:

ALM indicates Analog Linearizing Module

INPUT RANGE:

Minimum and maximum nominal input range
for 0 to 100% output.

OUTPUT RANGE:

Numbers: Minimum and maximum nominal
output range.

SC: Selectable Current (i.e., out-
put current range selectable
with one of several resistors
supplied for this purpose)

CURVE CHARACTERISTICS:

Indicates curve characteristic. (In this
instance, curve variable from $X = Y^1$ to
 $X = Y^3$)

POWER INPUT:

DC: DC power, 24 VDC $\pm 10\%$ unless
stated otherwise, e.g., 45 VDC

AC: AC power, 117 VAC $\pm 10\%$ unless
stated otherwise, e.g., 240 VAC

TABLE 1-2. EXPLANATION OF OPTION LETTERS IN MODEL NUMBER

-RO	Reversed Output
-KO	Internal "K" Factor

2.1 GENERAL INSTALLATION INFORMATION

Installation generally consists of calibration, mechanical mounting and making electrical connections to the unit. The remaining paragraphs of this section describe the necessary procedures.

2.2 CALIBRATION

All units are calibrated and checked for proper performance prior to leaving the factory. However, unless calibration to a specific set of input-output values were requested, the unit should be calibrated before placing in service.

NOTE

Adjustments should not be made in the field on units that are calibrated to values specified in the purchase order. Units that are calibrated at the factory to customer's specifications have protective caps over the SPAN and ZERO potentiometer. Do NOT remove these caps.

An adjustable input signal source and input and output monitoring devices are required for calibration. The monitoring devices must have an accuracy of 0.05% or better. The MII Test Set PTS-770 may be used as an output monitoring device.

NOTE

Refer to paragraph 1.6 for information on how to determine the specified minimum and maximum input and output levels and the applicable input and output functions.

To calibrate the unit, proceed as follows:

- a. Connect unit and test equipment as shown in Figure 2-1.
- b. Verify that the input signal source is set to zero. Apply power to the unit.
- c. Set input signal source to 0% input (1 VDC, 1 mA, DC, 4 mA, DC, 10 mA, DC). Monitor CAL 1 and adjust INPUT ZERO potentiometer for 0.00 volts.

- d. Set input signal source to 100% input (5 VDC, 5 mA DC, 20 mA DC or 50 mA DC) and adjust input SPAN potentiometer for a reading of 10 VDC at CAL 1.

NOTE

Since the adjustments of the INPUT ZERO and INPUT SPAN potentiometers interact, steps (c) and (d) should be repeated until readings remain at the desired levels for 0% and 100% inputs.

- e. Set input signal source to 100% input. Monitor CAL 2 and adjust AMPLITUDE potentiometer for 10 VDC.
- f. Set input signal source to 1% input. Adjust CHARACTER potentiometer for a voltage reading at CAL 2, derived by the following equation:

$$\text{CAL 2 VOLTAGE} = (\text{input \%})^N \times 10 \text{ volts}$$

where N = selected character between 1/5 and 5

EXAMPLE: With 1% input and N = .5

$$\text{The voltage at CAL 2} = (1\%)^{.5} \times 10 \text{ VDC} = 1 \text{ VDC}$$

NOTE

Since the adjustments of the AMPLITUDE and CHARACTER potentiometers interact, steps (e) and (f) should be repeated until the readings remain at the desired levels for 1% and 100 percent inputs.

- g. Set input signal source to 1%. Adjust OUTPUT ZERO potentiometer for the out percentage derived by the following equation:

$$\text{Output \%} = (\text{input \%})^N$$

EXAMPLE: With 1% input and N = .5 the output percentage = 10%. If the input is a voltage with a span of 1-5 VDC, 1% input = 1.4 VDC output. If the input is a current with a span of 4-20 mA DC, 1% input = 5.6 mA DC output.

- h. Set input signal source for 100% and adjust OUTPUT SPAN potentiometers for 100% output (5 VDC, 5 mA DC, 20 mA DC, 50 mA DC).

NOTE

Since the adjustments of the OUTPUT ZERO and OUTPUT SPAN potentiometers interact, steps (g) and (h) should be repeated until the readings remain at the desired output levels for 1% and 100% inputs.

2.3 MECHANICAL INSTALLATION

As mentioned in Section 1, the unit may be obtained in various physical configurations and/or case sizes. Figure 2-2 shows the outline dimensions and other installation requirements for the particular configuration supplied. Be sure to observe the applicable special procedures and precautions given with the illustration. Although the units are designed to operate in free air at quite a high ambient temperature, it is advisable if possible to mount the unit on a surface made of material that can serve as a heat sink. For a plug-in unit mounted in a rack, be sure that the rack has adequate ventilation.

2.4 ELECTRICAL CONNECTIONS

Except on plug-in units, all electrical connections are made to the terminal blocks in the unit. On plug-in units, the electrical connections are made to terminals on the mating connector for the unit. The terminals to be used for the electrical connections are indicated in Figure 2-3. The following paragraphs provide additional information on wiring the unit.

2.4.1 General Wiring Techniques

No special wire or cable is required for signal connections to the unit. To avoid transients and stray pickup, it is recommended that twisted conductors be used where they are run close to other services (such as power wiring). On open units supplied with a snap-off cover, dress all wiring up through the opening in the bottom of the cover. Spade-lug connectors are recommended for all wire terminations. All terminals are supplied with 6-32 screws long enough to easily accept three spade-lug connectors.

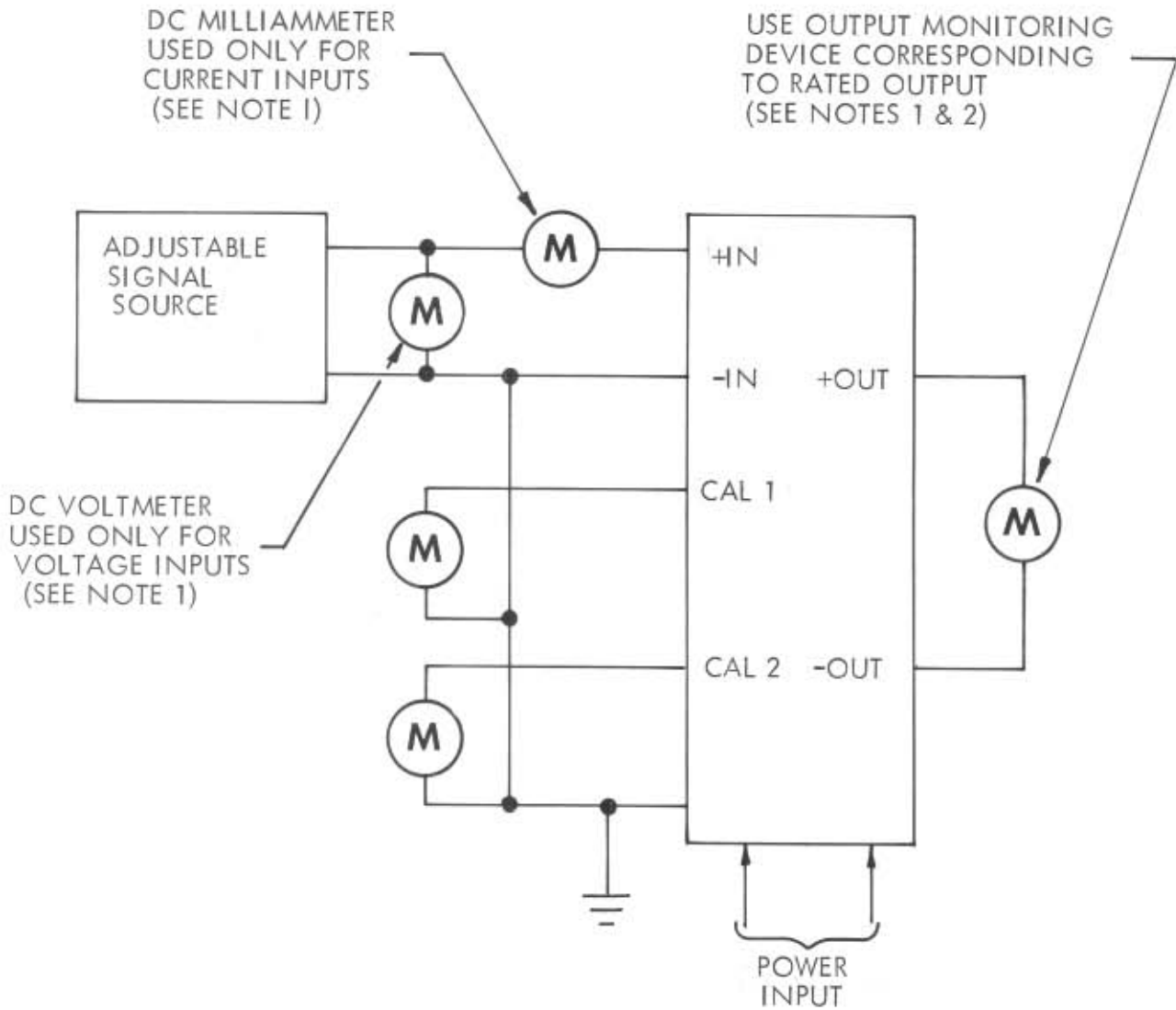

NOTES:

1. INPUT AND OUTPUT MONITORING DEVICES MUST BE ACCURATE TO WITHIN $\pm 0.05\%$ OR BETTER.
2. M.I.I. TEST SET PTS - 770 MAY BE USED FOR OUTPUT MONITORING DEVICE.

FIGURE 2-1 . Test Equipment Setup For
Calibration Of Unit

SECTION 2

CALIBRATION PROCEDURES

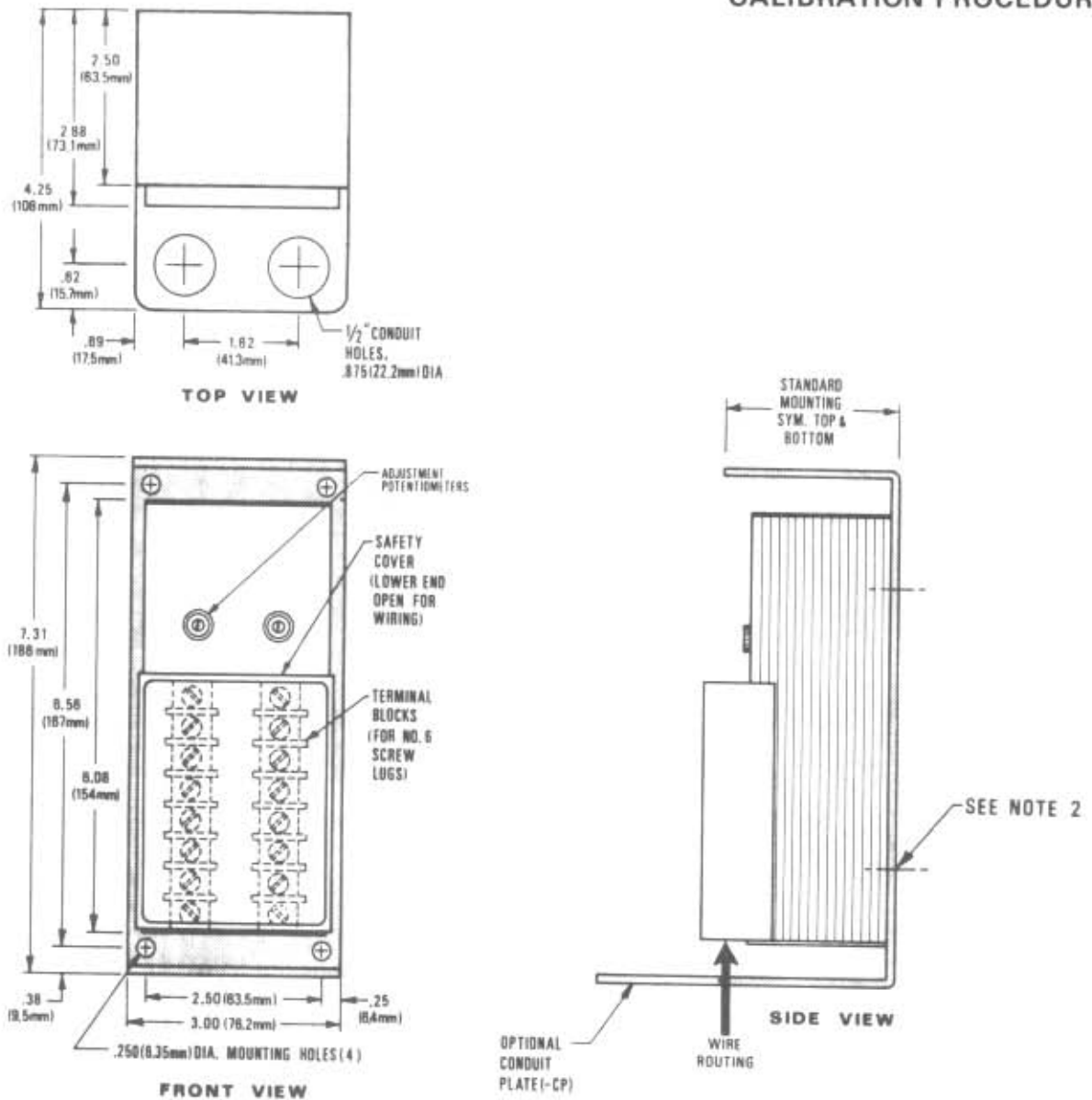

NOTES:

1. Complete Model No. and Serial No. are permanently marked on the identification plate located at the upper end of the terminal blocks.
2. When extra-compact mounting is required for rack or portable installation, the T-shaped mounting brackets may be removed and the two threaded inserts (located 4.00 inches apart) may be used for mounting, using 6-32 NC machine screws.

CAUTION

WHEN THE REAR INSERTS ARE USED FOR MOUNTING, BE SURE THAT THE MOUNTING SCREWS DO NOT PROTRUDE MORE THAN 1/8 INCH INTO THE UNIT.

Figure 2-2. Outline and Installation

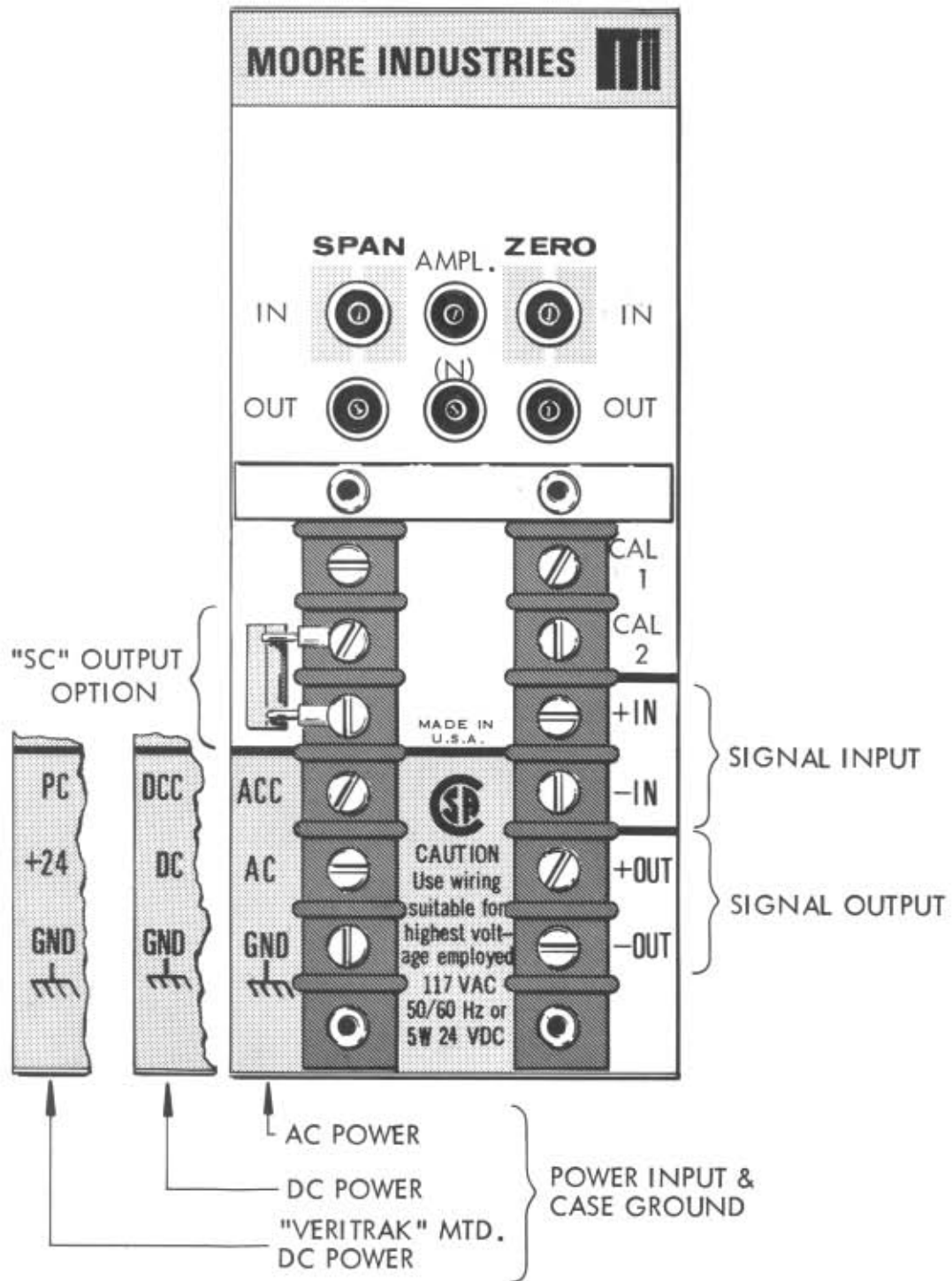

Figure 2-3 Electrical Connections For Standard Unit

2.4.2 Power Connections

A given unit is designed to be operated from either a DC power source, an AC power source, or an AC primary source with a backup power source that is put into use if the AC source should fail. Refer to paragraph 1.6 for information on how to use the model number to determine the type of power required.

On DC-powered units, the DC terminal is connected to the + (positive) side of the source, and the DCC terminal is connected to the - (negative) side. The DC source should be regulated to within $\pm 10\%$ of the nominal voltage and should be capable of delivering 5 watts.

On AC-powered units, 117 volts AC $\pm 10\%$, 50/60 Hz, 5 VA nominal power is required. The AC terminal should be connected to the ungrounded or "hot" side of the supply, if possible, and the ACC terminal is connected to the common or neutral side. The GND terminal is the mechanical case connection.

On AC-powered units with battery backup, connect the ACC and AC leads to terminals 4 and 5, respectively, and connect the battery backup leads DCC and DC to terminals 2 and 3, respectively.

2.4.3 Connections On Units With SC Option

On units with the SC (selectable current) option, connect the resistor to the terminals marked SC. If provided, the selectable current resistor for a plug-in unit is mounted externally either at the terminal block or soldered to the appropriate terminals on the PC connector.

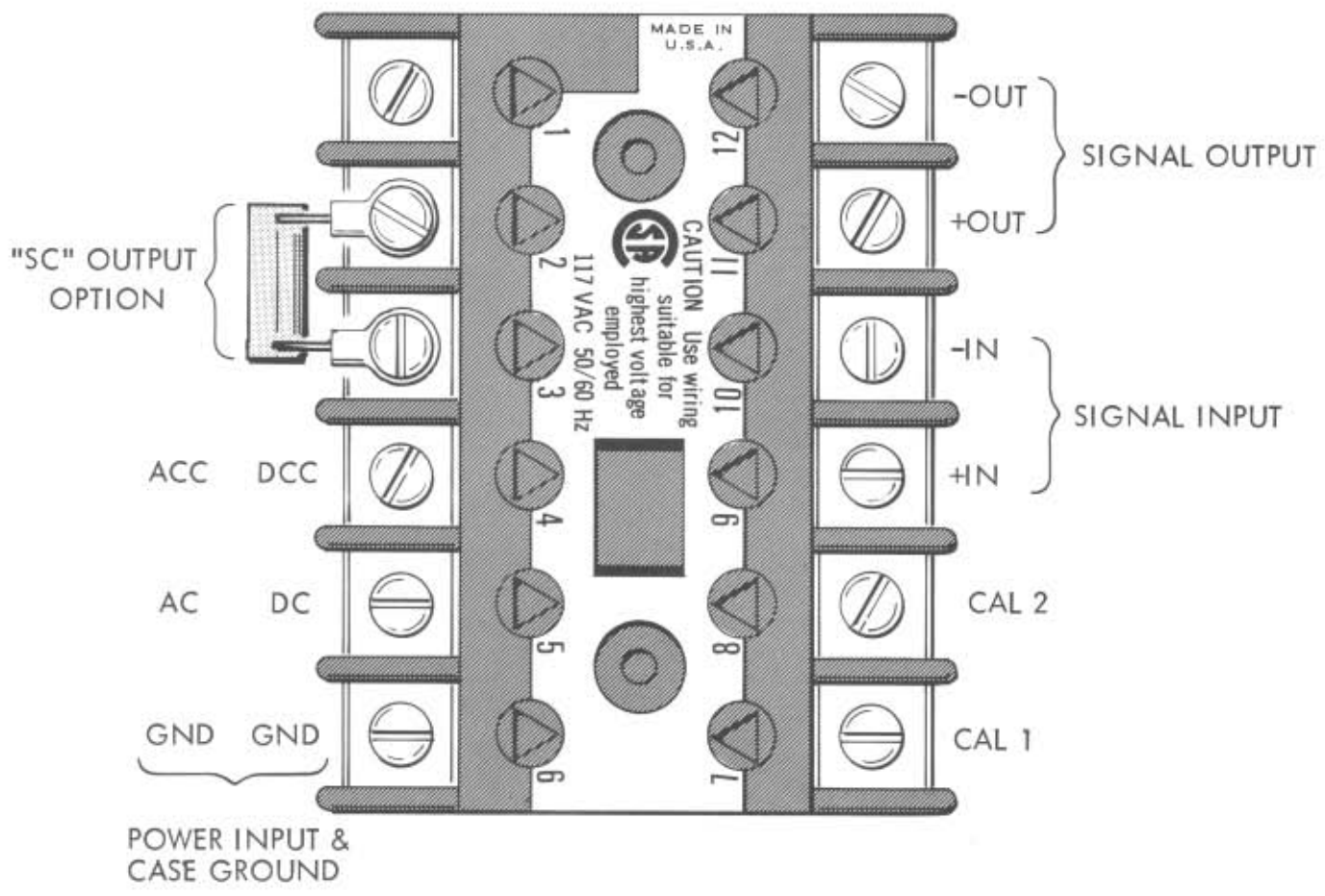

FIGURE 2-4 Electrical Connections For -EX (Explosion Proof) Housing Mounted Single Unit & -PST Std. Plug-In Units

3.1 OPERATING PROCEDURE

Once calibrated and installed, the unit may be operated unattended. There are six external controls, input and output zero and span controls, and amplitude and character controls. Output signal character (N) is adjusted in ranges: Range A, $N = 1-3$, Range B, $N = 3-5$, Range C, $N = 1 - 1/3$, Range D, $N = 1/3 - 1/5$. Ranges are selected by internal jumpers. Refer to schematic 158-406-00 for range selection information. Since this unit uses highly reliable solid-state components, it should operate virtually maintenance free for a long period of time. However, if a malfunction should occur, refer to Section 5 for maintenance information.

A unit may become warm during operation, especially where the ambient temperature is rather high. This is perfectly normal and should not be a cause for alarm unless a malfunction is also observed.

4.1 INTRODUCTION

This section gives a detailed description of all the circuitry utilized in the ALM. It is provided as an aid for troubleshooting.

4.2 CIRCUIT DESCRIPTION

Refer to the schematics at the end of the manual for the following circuit descriptions.

4.2.1 Description Of Power Supply Circuit (AC INPUT)

The power supply consists of power transformer, T2, line filter VS1, full-wave rectifier CR4-CR7 and diode CR1. VS1 across the primary of T2 filters out line transients. Voltage at secondary 8-10-13 is rectified by CR4-CR7 and coupled to regulator PC2 for the development of the + and -12 volt sources. The voltage from secondary 16-17 is rectified by CR1, filtered by C5 then coupled to circuit point C as the +38 volt supply.

4.2.2 Description Of Power Supply Circuit (DC INPUT)

The DC applied to DC and DCC is converted to a 3-KHz square wave by Q2, Q3, T1 and associated circuitry. Capacitors C2 and C3 and inductor L1 comprise a filter. Diode CR3 protects the circuit against voltages of the wrong polarities being applied. The AC at secondary winding 16-17 is rectified by CR1, filtered by C5, then coupled to point C as the +38 volt supply. The AC at secondary winding 8-10-13 is rectified by CR4-CR7 then filtered by C7 and C6, then coupled to regulator PC2 for the development of the + and -12 volt sources.

4.2.3 Description Of Power Supply Regulator Circuit (PC2)

Unregulated voltage is applied to the voltage regulator at circuit points 5 and 6. The power supply regulator consists of two essentially identical circuits, one producing +12 volts and the other -12 volts. Since the two circuits are identical, only the +12 volt regulator will be explained. The regulator is comprised of error amplifier IC202 and series pass transistor Q204. Over-current protection is provided by transistor Q203. Reference for the regulator is provided by zener diode CR201. The regulated output is divided across R211 and R214 thereby developing a differential voltage across the inputs of IC202 (approximately 3 volts when current is operating normally). A change at the regulator output is sensed at pin 2 of IC202 and therefore, at pin 6. This change in voltage at the output (pin 6) of IC202 affects the amount of current to the base of Q204. Thus, the current through Q204 changes proportionally to the base current and the regulated output is varied to correct for the sensed error. An over-current condition causes normally non-conducting Q203 to conduct. It continues to conduct until the regulated output goes to 0 volt at which time Q204 turns off. Pass transistor Q204 stays off until the over-current condition is remedied.

4.2.4 Description Of Input Amplifier Circuit

The monotonic curve to be shaped is applied to the non-inverting input of IC2. Feedback for the amplifier is taken through R7 and the INPUT SPAN potentiometer to the inverting input (pin 2). Maximum input level and therefore the amplifier gain is adjusted by the INPUT SPAN potentiometer. Minimum input level is adjusted by the INPUT ZERO potentiometer. Resistor R18 is present only for current inputs. The circuit operates from + and -12 volts.

4.2.5 Description Of Function Generation Circuit

Shaping of the output voltage or current curve is accomplished by the Function Generation Circuit. The Function Generation Circuit, mounted on printed circuit board PC3, is comprised of IC301 through IC304, transistors Q302, Q301 and associated components. The character or N of the output curve is determined by the configuration of jumpers J303, J304, J302 and J301. When J303 and J301 are jumpered, the character of the output signal is a root of the input signal. However, when J304 and J302 are jumpered the output signal is a power of the input. (X^1 to X^5)

Integrated circuits IC303 and IC301 together with Q302A and Q302B and associated components, generate a logarithmic output voltage when a linear signal is applied at pin 2 (inverting input) of IC303. Negative feedback for IC303 is applied to the emitter of Q302A by way of the CHARACTER potentiometer or J301 and the emitter-base junction of transistor Q302B. Thus, the collector current of Q302A is equal to the current through R311 which varies with the input signal. Since Q302B is in the feedback loop of amplifier IC301, the collector current through Q302B is constant by the fixed voltage applied at circuit point A (+12 volts). With the collector current of Q302B held constant the emitter-base voltage is also constant. Since only the emitter-base voltage of Q302A varies with the input, the logarithmic output at pin 6 of IC301 is the difference between the fixed V_{BE} of Q302B and the variable V_{BE} of Q302A.

This logarithmic output drives transistor Q301 via J302 or the CHARACTER potentiometer on J304, depending on the jumper configuration. Integrated circuits IC302 and IC304, Q301A and B comprise an antilog circuit which generates an output of from 0 to 10V from the log generator input. Amplifier IC304 in conjunction with Q301A drives the emitter of Q301B in proportion to the input voltage at the base of Q301A. The collector current of Q301B varies exponentially with the emitter-base voltage. This current is converted to a voltage by amplifier IC302 & R307. The maximum output level of the Function Generation Circuit is adjusted by the AMPLITUDE potentiometer and the character or N of the output signal is adjusted by the CHARACTER potentiometer.

4.2.6 Description Of IC6 Circuit

The shaped voltage or current curve from the function circuit is applied to the non-inverting input (pin 3) of IC1. Feedback for the amplifier is taken through the base-emitter junctions of Q1 and Q5 (current output) or the base-emitter junctions of Q4 (voltage output) to the inverting input (pin 2). The gain of the amplifier and thus the 100% output level is set by the OUTPUT SPAN potentiometer. The OUTPUT ZERO potentiometer is connected between +12 volts and ground and adjusts the 0% output level (1 VDC, 1mA DC, 4 mA DC). IC1 operates from + and -12 volts.

4.2.7 Description Of Power Amplifier Circuit

In the current output configuration the power amplifier is comprised of Darlington pair Q1 and Q5 and associated circuitry. The current output is taken across R16. When the SC option is included, the selectable resistor replaces R13. In the voltage output configuration, the output amplifier is comprised of emitter follower Q4 and its associated components. The voltage output is taken at +V and -V, across R13. The power amplifier operates from +38 volts.

5.1 INTRODUCTION

This section contains information on maintenance of the unit. General troubleshooting procedures are given, using conventional signal-tracing techniques. Precautions and special techniques used to replace components are also described.

5.2 PERIODIC MAINTENANCE

It is suggested that the calibration of the unit be checked approximately every 6 months as described in Section 2. No other periodic maintenance is required.

5.3 CORRECTIVE MAINTENANCE

The following paragraphs provide information on corrective maintenance of the unit. Corrective maintenance should be carried out only by qualified personnel who have read and thoroughly understand the description of circuit operation given in Section 4.

5.3.1 Disassembly

To troubleshoot the unit, it is first necessary to disassemble it so the circuit board is exposed. The physical configuration of the unit determines the steps to be followed in disassembly and are described in the following paragraphs. In all cases, disconnect input signal and turn off primary power before disassembling unit.

5.3.1.1 Disassembly Of Standard And -CP Units

To disassemble a standard of -CP unit, remove the unit from its installed position. If the mounting bracket is used, separate it from the unit by removing the two counter-sunk screws at the rear of the unit. After the unit has been removed from its installed position, disassemble the unit as follows to gain access to the circuit board:

- a. Remove the two front Phillips-head screws at the top of the unit.
- b. Remove the four Phillips-head screws at the bottom of the unit.
- c. Slide the front panel (with the circuit board still attached) down and free of the sides of the case. Points on the circuit board may now be reached for troubleshooting. It is suggested that the case be used as a container for storing the removed hardware.

5.3.1.2 Disassembly Of A Plug-In Unit With A -PC Housing

To remove the cover of a plug-in unit with a -PC housing, proceed as follows:

- a. Gently spread the forward locking feet and lift the front of the cover NO MORE THAN 1/4 INCH. Excessive force applied to the cover may break the rear retaining clips.
- b. With the front of the cover raised, slide the cover to the rear to disengage it from the plug-in card.

If it is desired to test a plug-in unit in the operating position, a circuit-board extender (Part No. 350-206-00 or equivalent) is required to bring the unit forward so the components on the circuit board are accessible for troubleshooting.

5.3.1.3 Disassembly Of A Plug-In Unit In A Housing

To disassemble a plug-in unit in an explosion-proof or other type of housing or enclosure (in addition to the case) proceed as follows:

- a. Use a bar wrench to loosen the housing cover from the base, then unscrew and remove the housing cover to expose the unit.
- b. If required, remove the unit from the socket by rocking the unit slightly while pulling upward until it is free of the socket. The socket and terminal card are keyed to eliminate error when the unit is reinstalled.

5.3.2 Troubleshooting

The schematic diagram(s) includes flagged numbers at various points in the circuit. Table 5-1 gives the voltages and waveforms at these points for specified input-signal conditions. The assembly drawing(s) (immediately after the schematic diagram) shows the physical location of the parts on the circuit board. Bear in mind that the circuit board is protected with a moisture-resistance coating. Therefore, it may be necessary to use a needle-point probe and exert a fair amount of pressure to break through the coating when it is desired to observe the signal or voltage at a specific point. When connecting a probe to a component on the circuit board, exercise care to make sure the probe does not short-circuit to an adjacent component. In general, troubleshooting is carried out by tracing the signal with an oscilloscope

and referring to the schematic diagram(s) to determine what component might be causing an observed abnormal indication. If the original symptom was a complete failure of the unit to operate, the most logical place to look for trouble is in the power converter. If the unit was producing an incorrect (but not zero) output, check the outputs from the power converter and, if these are normal, apply a standard input signal and trace the resulting signal through the unit.

NOTE

Do NOT adjust sealed potentiometer(s) on circuit boards unless absolutely necessary. For the procedure to determine if such a potentiometer requires readjustment and for the adjustment procedure itself, refer to paragraph 5.3.3.

5.3.3 Component Replacement Techniques And General Precautions

Replace all defective components with identical parts. Refer to the assembly drawing(s) for a list of replacement parts. The letter S and a number, all enclosed in a circle, appear after the description of certain parts in this list. The number indicates the number of spares recommended to be kept on hand for that part, per unit, for up to ten units of the same type. For more than ten units, a spares complement of 10% on the indicated parts should be used.

Most parts used in the unit are quite small and are located in a confined area. Therefore, small hand tools are a necessity when servicing the unit. The following is a summary of the general techniques and precautions that should be observed to prevent damage to components in the unit:

- a. Use a transformer-operated low-voltage soldering iron with a grounded tip and rated at not more than 50 watts. A temperature-controlled tip is desirable.
- b. Use extreme care when unsoldering the leads to any component. Do not keep the soldering iron on a point for more than a few seconds at a time. Use a suction-type solder-removing tool (solder sucker) as an aid in unsoldering transistors and integrated circuits. The protective coating on the unit may be removed with trichlorethane or equivalent. Be sure adequate ventilation is provided when using this or any other chemical.

NOTE

Unused connections on integrated circuits are left unsoldered to aid in removal. Refer to the assembly drawing(s) for more complete information.

- c. Do not excessively bend or twist the leads of small components; they break easily.
- d. Before removing a component, observe the lead dress. Be sure that the lead dress of the replacement is the same as that of the original.
- e. Handle MOSFET's only by the case; if the fingers are allowed to contact the leads, the MOSFET may be ruined. Be sure to leave the metal sleeve around the leads until just before the device is installed on the printed circuit board.
- f. Remove all flux from soldered joints with trichlorethane or equivalent.

NOTE

Units that were calibrated at the factory to customer's specifications have protective caps over the SPAN and ZERO potentiometers. These caps must be removed so the unit can be recalibrated. LIFT, DO NOT TWIST the caps off, using a screwdriver tip as a prying tool. Snap the caps back in place, WITHOUT TWISTING, WHEN RECALIBRATION has been completed.

- g. Test and, if necessary, recalibrate the unit by the procedure given in Section 2. When the performance of the unit is known to be satisfactory, apply clear acrylic to reseal the unit where required.
- h. Check that all leads are clear of the board edge before reinstalling the board into its case.
- i. When reinstalling the unit onto the mounting bracket, be sure to use the same screws (or screws of the same size) as the one removed. Longer screws will damage the unit.

TABLE 5-1. WAVEFORM & VOLTAGES

TEST POINT	AMPLITUDE *
1	0-10 VDC
2	0-120 MVDC
3	-.4 TO -.6 VDC
4	0-10 VDC
5	4-11 VDC
6	1-5 VDC

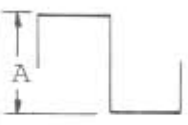
TEST POINT	WAVEFORM	POWER INPUT AMPLITUDE		
		24 VDC	45 VDC	65 VDC
7		A = 48V _{pp}	A = 90V _{pp}	S=130V _{pp}

* NOTE: VOLTAGES AT TEST POINT 1 THROUGH 6 ARE FOR AN INPUT OF 1 TO 5 V. THE SMALLER OF THE TWO VALUES IS FOR 1 VOLT IN AND THE LARGER IS FOR 5 VOLTS IN.

TABLE 5-2 POWER SUPPLY VOLTAGES

TEST POINT	VOLTAGE LEVEL
A	+ 12 VDC
B	- 12 VDC
C	+6.2 VDC



MOORE INDUSTRIES
16650 Schoenborn Street
Sepulveda, California 91343

DO NOT SCALE DRAWING

TOLERANCES
UNLESS NOTED
X ±.1
XX ±.03
XXX ±.010
ANGLES ±30°

DRAWN	DATE
CHECKED	
ENGINEER	
SCALE	

PLUG-IN
ALM

DRAWING NUMBER

158-451-00

REVISION

B

CATEGORY

SCHEMATIC

REVISED BY

SEE SH.1

DATE

BY

APPROVED

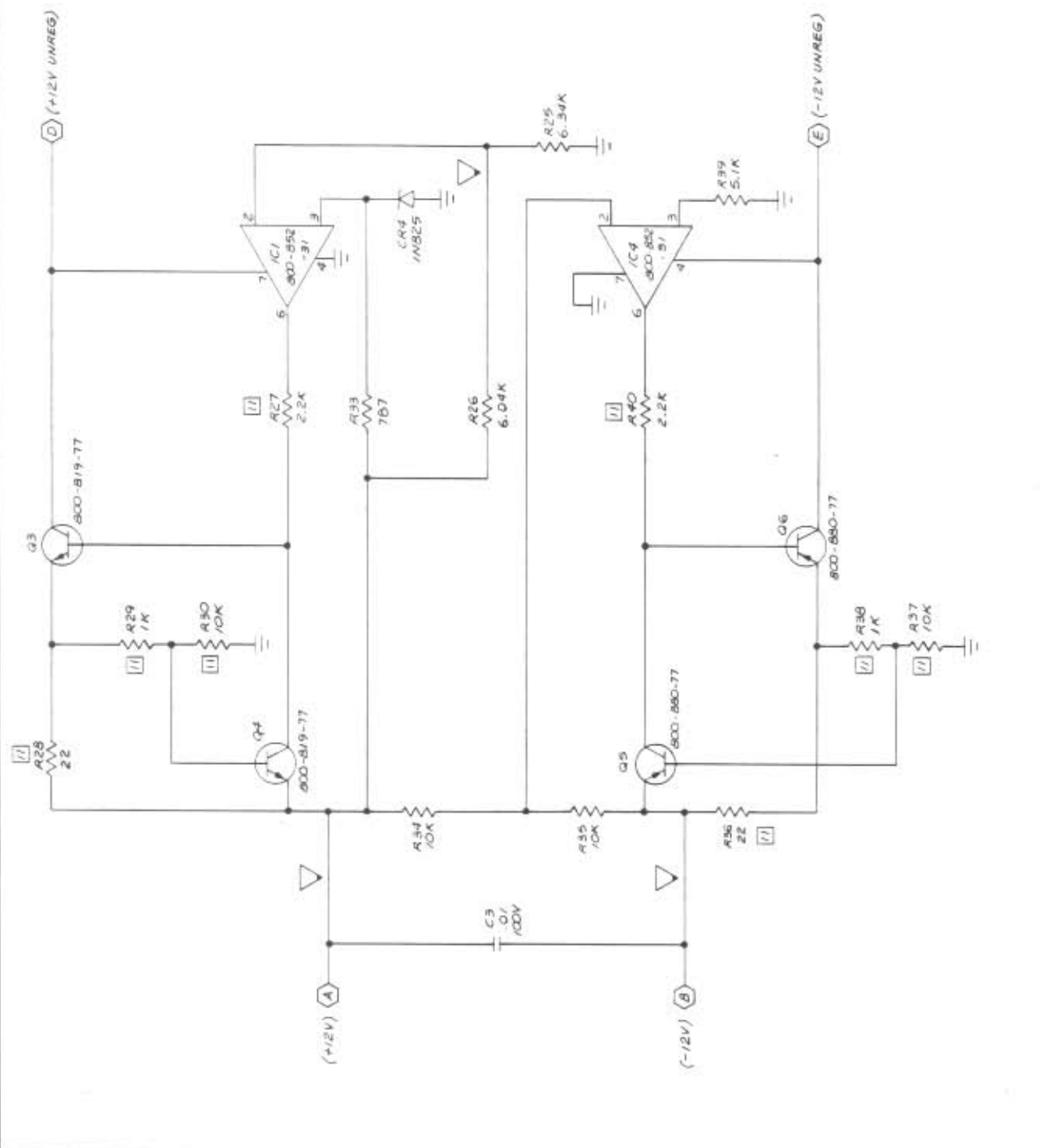

MOORE INDUSTRIES
 16650 Schoenborn Street
 Sepulveda, California 91343

DO NOT SCALE DRAWING

TOLERANCES UNLESS NOTED	DATE	BY
X ±.1	10/27/81	WPC
XX ±.03		
XXX ±.010		
ANGLES ±30'		
FORM	2/1	

ALM
 PLUG-IN
 PCI

DESIGN NO.	158-551-00	REV.	E
DESCRIPTION	ASSEMBLY		
DATE	10/27/81	BY	WPC

8450 FILE COMP. INSTR. CA MANUFACTURE

158-551-00
 ASSEMBLY

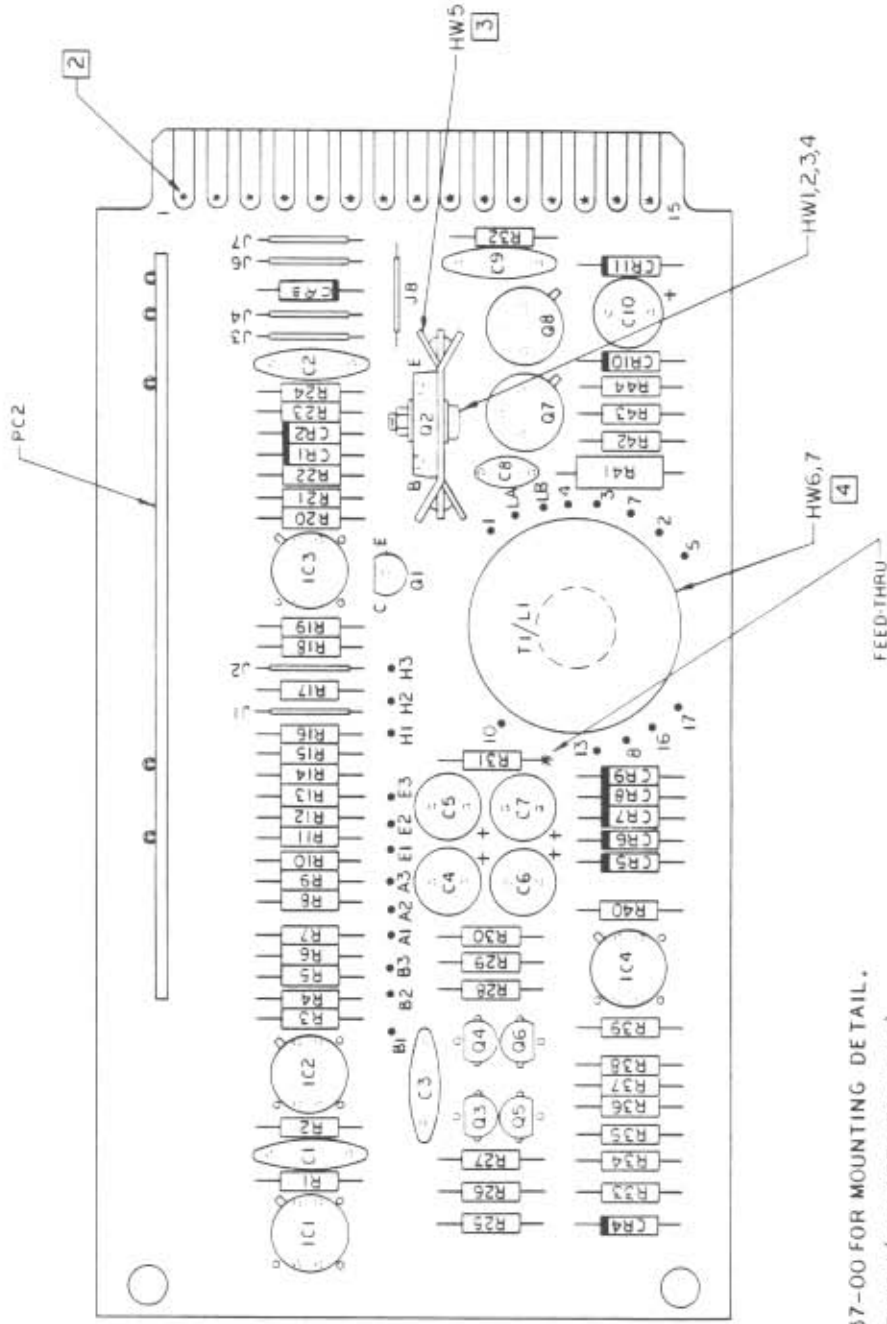

- [4] SEE 200-237-00 FOR MOUNTING DETAIL.
 - [3] TRIM EARS FLUSH.(2 PLACES, FAR SIDE)
 - [2] INSTALL 22AWG BUSS. (15 PLACES MARKED *)
 *. SOLDER ALL LEADS AND TERMINALS TO PADS.
- NOTES:



MOORE INDUSTRIES
18650 Schoenborn Street
Sepulveda, California 91343

DO NOT SCALE DRAWING

TOLERANCES
UNLESS NOTED
X ± .1
XX ± .03
XXX ± .010
ANGLES ± 30°

DATE: *10/21/81*
DESIGNER: *W. J. ...*
ENGINEER: *...*
SCALE: 2/1

ALM
PLUG-IN
PC2

DRAWING NUMBER: 158-552-00
CATEGORY: ASSEMBLY
REVISED BY: INITIAL RELEASE
DATE: 10/21/81
BY: D
APPROVAL: *ML*

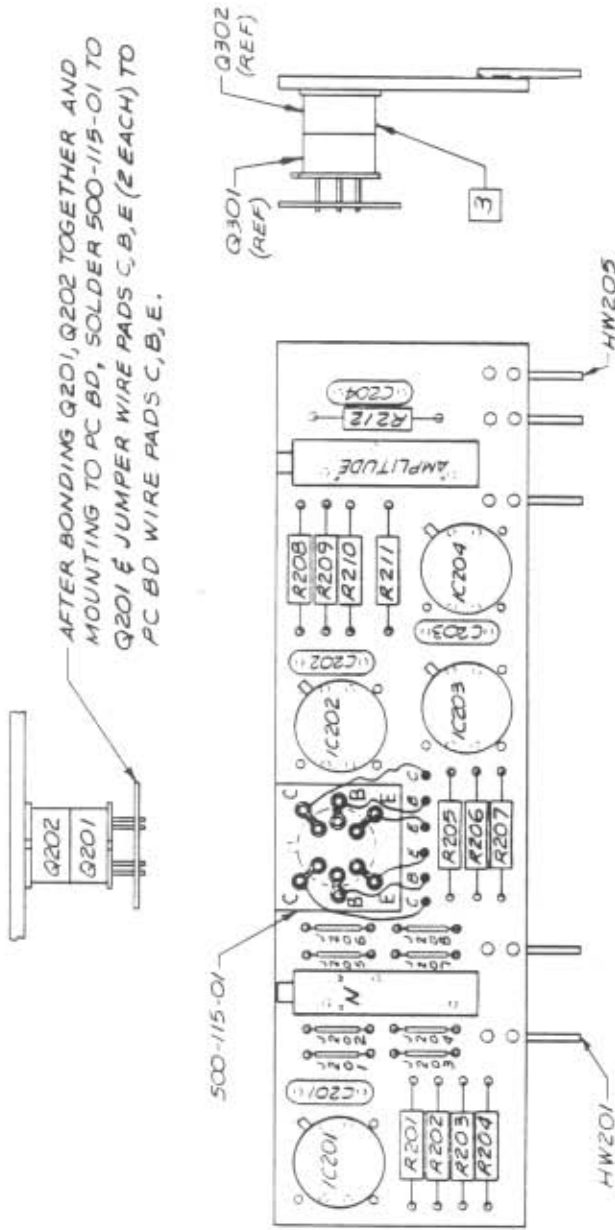

AFTER BONDING Q201, Q202 TOGETHER AND MOUNTING TO PC BD, SOLDER 500-115-01 TO Q201 & JUMPER WIRE PADS C, B, E (2 EACH) TO PC BD WIRE PADS C, B, E.

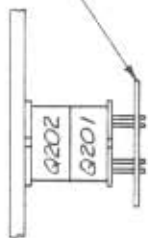

- 3 BOND Q201 & Q202 TOGETHER, USING EASTMAN 910 OR EQUIV, BEFORE ASSEMBLING TO PC BOARD.
 2. JUMPERS TO BE 22 AWG, TEFLON SLEEVED.
 1. SOLDER ALL LEADS TO PADS.
- NOTES:



MOORE INDUSTRIES
16650 Schoenborn Street
Sepulveda, California 91343

DO NOT SCALE DRAWING

TOLERANCES

X ± .1
XX ± .03
XXX ± .010
ANGLES ± 30°

DATE 1/20/78
SCALE 2/1

STANDARD

ALM
PCI

DRAWING NUMBER 158-506-00

CATEGORY P.C. ASSEMBLY

REVISED BY ECO 5561

DATE 3/1/78

BY

APPROVAL

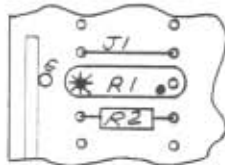

R1 DETAIL

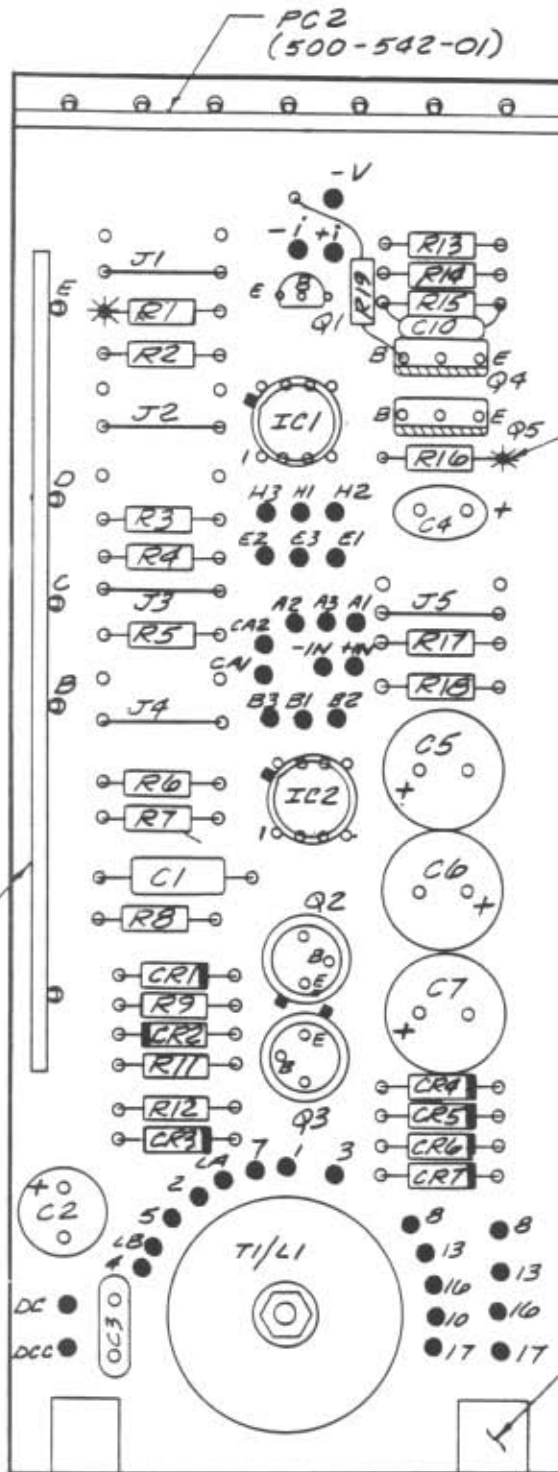

+V DETAIL

FEED THRU WHEN NOT USED

SOLDER LEADS TOGETHER

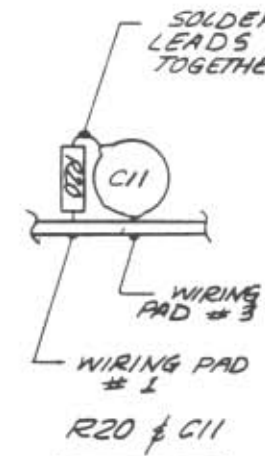

WIRING PAD #3
WIRING PAD #1
R20 & C11

PC3 (158-507-01)

4 2 PLCS

- 4 MOUNT SWAGE BLOCKS ON P.C. BOARD BEFORE ADDING COMPONENTS. SEE CASE ASSEMBLY FOR POSITION.
3. [Symbol] INDICATES METALIZED SIDE OF Q4 AND Q5.
2. ALL LEADS MUST BE SOLDERED TO P.C. BOARD
1. ALL JUMPERS 22AWG BUSS, TEFLON SLEEVED AS REQ'D.
- NOTES:

TOLERANCES UNLESS NOTED	
X	± .1
XX	± .03
XXX	± .010
ANGLES ± 30°	

DESIGNED BY	G. TESSE
CHECKED BY	
DATE	7/17/70
SCALE	2/1

STANDARD
 ALM
 (SHEET 2)

MOORE NUMBER	158-506-00	REV. 001	D
DATE	ASSEMBLY		
REVISED BY	SEE SHEET 1		

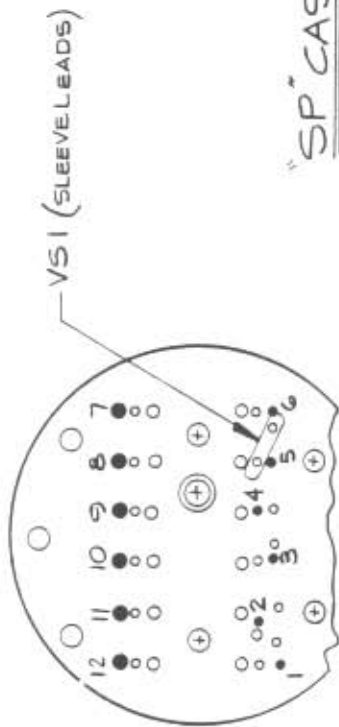

"SP" CASE

VSI

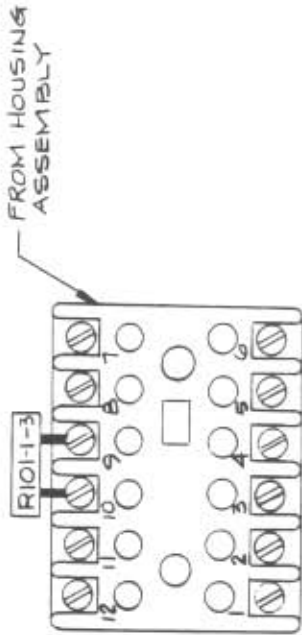

RIOI-1 THRU RIOI-3 (SAME POSITION)

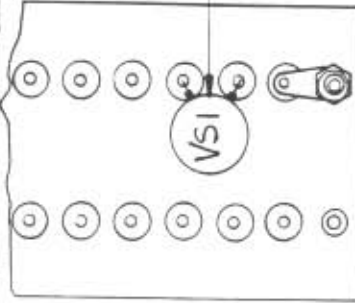
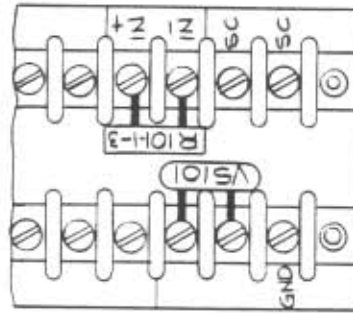

VSI, RIOI-1 THRU-3
 (RIOI IS SAME POSITION FOR ALL THREE.)

VSI (REAR SIDE SHOWN)

NOTES: (SEE SHEET ONE).

"SR & PM" CASE



MOORE INDUSTRIES
 16650 Schoenborn Street
 Sepulveda, California 91343

DO NOT SCALE DRAWING

TOLERANCES
 UNLESS NOTED
 .X ±.1
 .XX ±.03
 .XXX ±.010
 ANGLES ±.30°

DESIGNED BY	1/9/79
CHECKED	
ENGINEER	
SCALE	

STANDARD

ALM

PC3

DRAWING NUMBER
 158-507-00

CATEGORY
 P.C. ASSEMBLY

REVISION BY
 ECO 3693

DATE	5/29/79
BY	D
APPROVAL	AKB

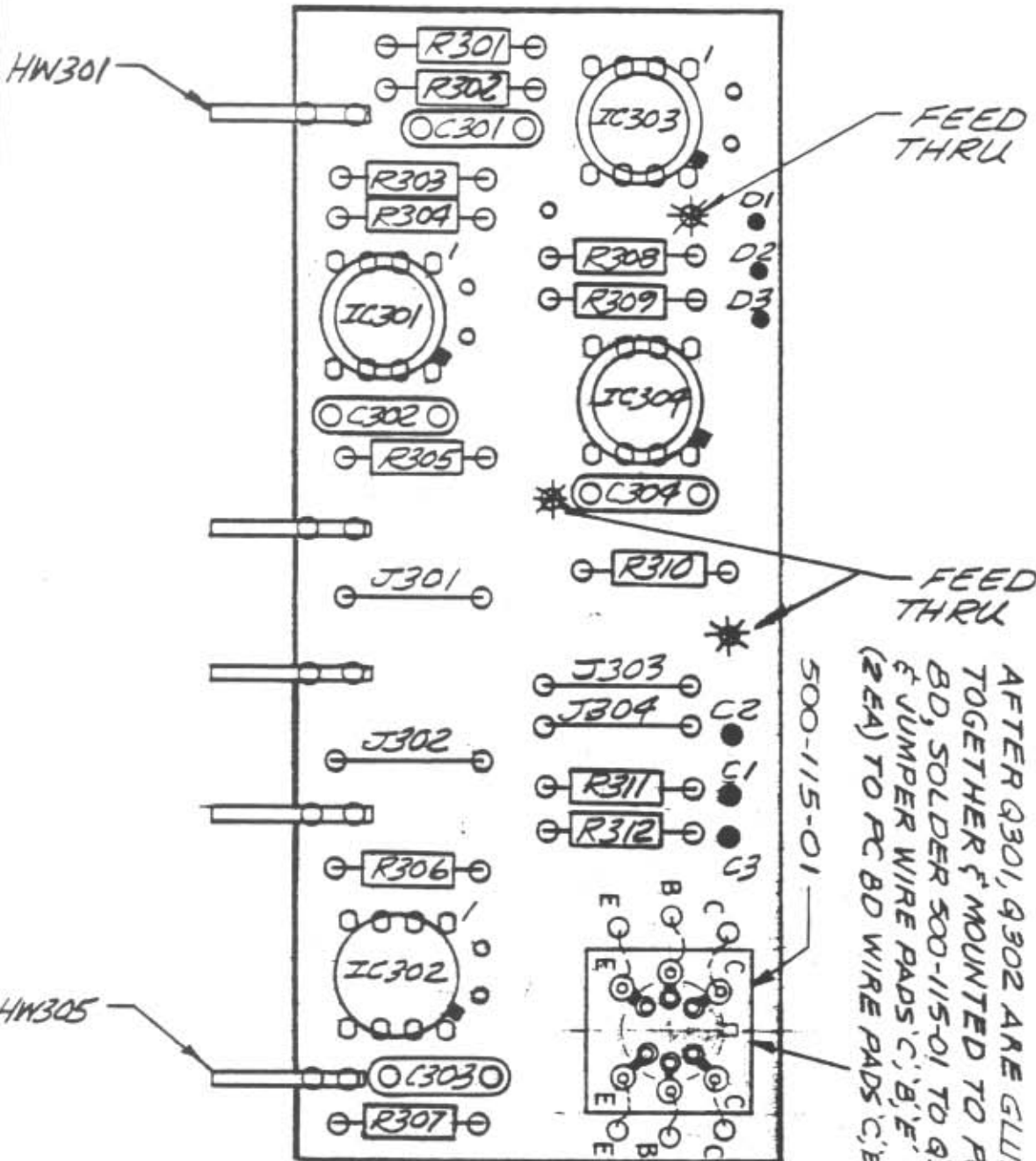

AFTER Q301, Q302 ARE GLUED TOGETHER & MOUNTED TO PC BOARD, SOLDER 500-115-01 TO Q301 & JUMPER WIRE PADS 'C', 'B', 'E' (2EA) TO PC BOARD WIRE PADS 'C', 'B', 'E'.

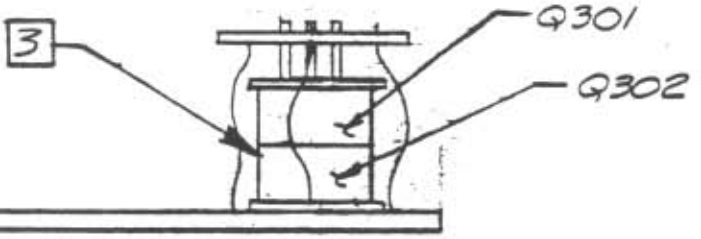

TRIM EXCESS TYP.

- 3 Q301 & Q302 ARE GLUED TOGETHER WITH PERM-BEFORE ASSEMBLY ON P.C. BOARD.
2. ALL LEADS MUST BE SOLDERED TO PADS.
1. ALL JUMPERS 22 AWG AS REQ'D.
- NOTES:

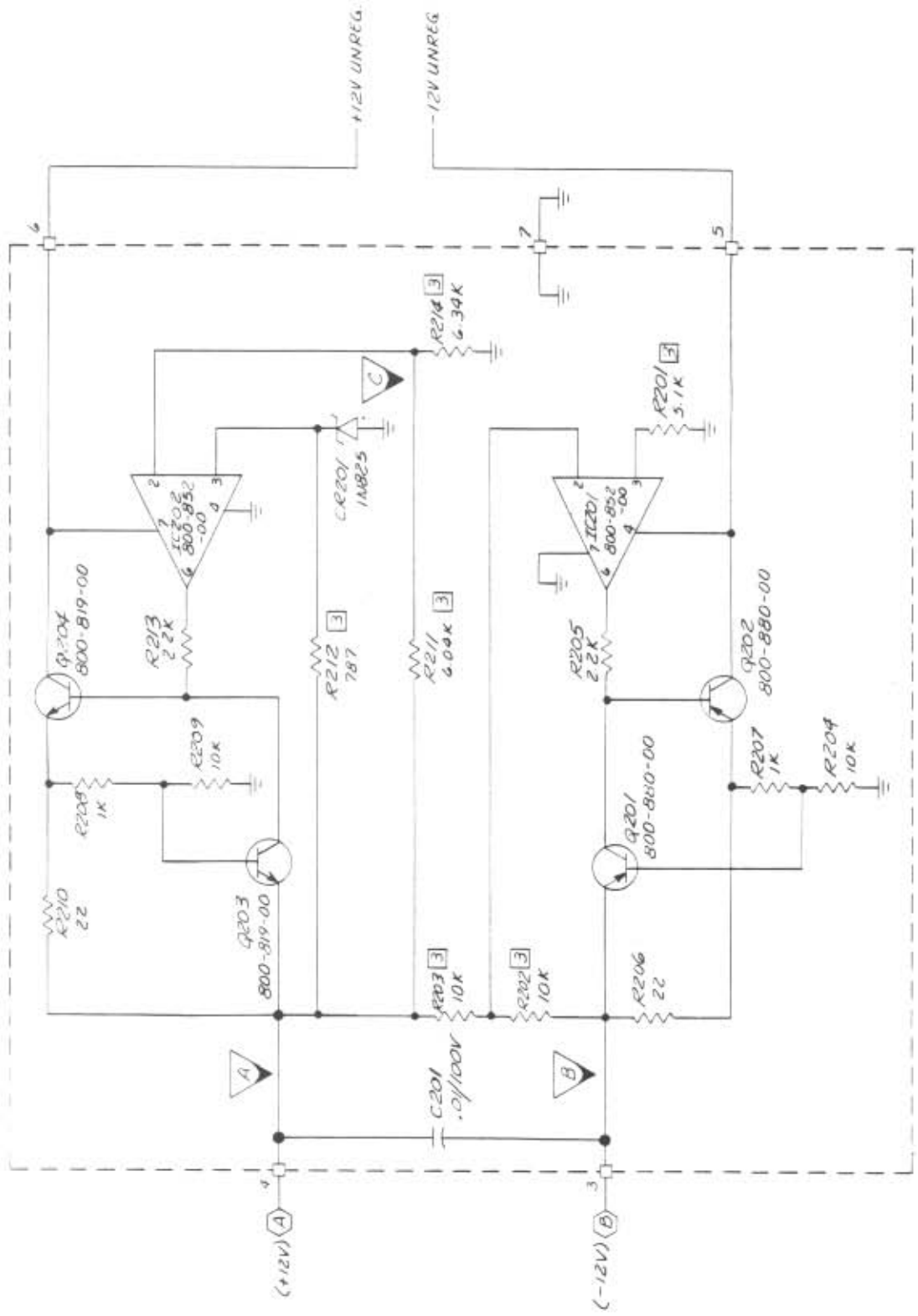

ITEM NO	ITEM PART NUMBER	LIST OF MATERIALS	MANUFACTURER	REFERENCE DESIGNATION
1	741	IC 741	MOORE INDUSTRIES INC.	U1
2	742	IC 742	MOORE INDUSTRIES INC.	U2
3	R201	2.2K	MOORE INDUSTRIES INC.	R201
4	R206	22K	MOORE INDUSTRIES INC.	R206
5	R207	1K	MOORE INDUSTRIES INC.	R207
6	R204	10K	MOORE INDUSTRIES INC.	R204
7	R210	22K	MOORE INDUSTRIES INC.	R210
8	R208	1K	MOORE INDUSTRIES INC.	R208
9	R209	10K	MOORE INDUSTRIES INC.	R209
10	R213	2.2K	MOORE INDUSTRIES INC.	R213
11	C201	.01/100V	MOORE INDUSTRIES INC.	C201
12	R211	6.09K	MOORE INDUSTRIES INC.	R211
13	R212	787	MOORE INDUSTRIES INC.	R212
14	R214	6.34K	MOORE INDUSTRIES INC.	R214
15	R205	2.2K	MOORE INDUSTRIES INC.	R205
16	R202	10K	MOORE INDUSTRIES INC.	R202
17	R203	10K	MOORE INDUSTRIES INC.	R203
18	R220	1K	MOORE INDUSTRIES INC.	R220
19	Q203	800-819-00	MOORE INDUSTRIES INC.	Q203
20	Q201	800-810-00	MOORE INDUSTRIES INC.	Q201
21	Q202	800-880-00	MOORE INDUSTRIES INC.	Q202
22	Q204	800-819-00	MOORE INDUSTRIES INC.	Q204
23	C201	.01/100V	MOORE INDUSTRIES INC.	C201
24	R210	22K	MOORE INDUSTRIES INC.	R210
25	R208	1K	MOORE INDUSTRIES INC.	R208
26	R209	10K	MOORE INDUSTRIES INC.	R209
27	R213	2.2K	MOORE INDUSTRIES INC.	R213
28	C201	.01/100V	MOORE INDUSTRIES INC.	C201
29	R211	6.09K	MOORE INDUSTRIES INC.	R211
30	R212	787	MOORE INDUSTRIES INC.	R212
31	R214	6.34K	MOORE INDUSTRIES INC.	R214
32	R205	2.2K	MOORE INDUSTRIES INC.	R205
33	R202	10K	MOORE INDUSTRIES INC.	R202
34	R203	10K	MOORE INDUSTRIES INC.	R203
35	R207	1K	MOORE INDUSTRIES INC.	R207
36	R204	10K	MOORE INDUSTRIES INC.	R204
37	Q203	800-819-00	MOORE INDUSTRIES INC.	Q203
38	Q201	800-810-00	MOORE INDUSTRIES INC.	Q201
39	Q202	800-880-00	MOORE INDUSTRIES INC.	Q202
40	Q204	800-819-00	MOORE INDUSTRIES INC.	Q204
41	C201	.01/100V	MOORE INDUSTRIES INC.	C201
42	R210	22K	MOORE INDUSTRIES INC.	R210
43	R208	1K	MOORE INDUSTRIES INC.	R208
44	R209	10K	MOORE INDUSTRIES INC.	R209
45	R213	2.2K	MOORE INDUSTRIES INC.	R213
46	C201	.01/100V	MOORE INDUSTRIES INC.	C201
47	R211	6.09K	MOORE INDUSTRIES INC.	R211
48	R212	787	MOORE INDUSTRIES INC.	R212
49	R214	6.34K	MOORE INDUSTRIES INC.	R214
50	R205	2.2K	MOORE INDUSTRIES INC.	R205
51	R202	10K	MOORE INDUSTRIES INC.	R202
52	R203	10K	MOORE INDUSTRIES INC.	R203
53	R207	1K	MOORE INDUSTRIES INC.	R207
54	R204	10K	MOORE INDUSTRIES INC.	R204
55	Q203	800-819-00	MOORE INDUSTRIES INC.	Q203
56	Q201	800-810-00	MOORE INDUSTRIES INC.	Q201
57	Q202	800-880-00	MOORE INDUSTRIES INC.	Q202
58	Q204	800-819-00	MOORE INDUSTRIES INC.	Q204
59	C201	.01/100V	MOORE INDUSTRIES INC.	C201
60	R210	22K	MOORE INDUSTRIES INC.	R210
61	R208	1K	MOORE INDUSTRIES INC.	R208
62	R209	10K	MOORE INDUSTRIES INC.	R209
63	R213	2.2K	MOORE INDUSTRIES INC.	R213
64	C201	.01/100V	MOORE INDUSTRIES INC.	C201
65	R211	6.09K	MOORE INDUSTRIES INC.	R211
66	R212	787	MOORE INDUSTRIES INC.	R212
67	R214	6.34K	MOORE INDUSTRIES INC.	R214
68	R205	2.2K	MOORE INDUSTRIES INC.	R205
69	R202	10K	MOORE INDUSTRIES INC.	R202
70	R203	10K	MOORE INDUSTRIES INC.	R203
71	R207	1K	MOORE INDUSTRIES INC.	R207
72	R204	10K	MOORE INDUSTRIES INC.	R204
73	Q203	800-819-00	MOORE INDUSTRIES INC.	Q203
74	Q201	800-810-00	MOORE INDUSTRIES INC.	Q201
75	Q202	800-880-00	MOORE INDUSTRIES INC.	Q202
76	Q204	800-819-00	MOORE INDUSTRIES INC.	Q204
77	C201	.01/100V	MOORE INDUSTRIES INC.	C201
78	R210	22K	MOORE INDUSTRIES INC.	R210
79	R208	1K	MOORE INDUSTRIES INC.	R208
80	R209	10K	MOORE INDUSTRIES INC.	R209
81	R213	2.2K	MOORE INDUSTRIES INC.	R213
82	C201	.01/100V	MOORE INDUSTRIES INC.	C201
83	R211	6.09K	MOORE INDUSTRIES INC.	R211
84	R212	787	MOORE INDUSTRIES INC.	R212
85	R214	6.34K	MOORE INDUSTRIES INC.	R214
86	R205	2.2K	MOORE INDUSTRIES INC.	R205
87	R202	10K	MOORE INDUSTRIES INC.	R202
88	R203	10K	MOORE INDUSTRIES INC.	R203
89	R207	1K	MOORE INDUSTRIES INC.	R207
90	R204	10K	MOORE INDUSTRIES INC.	R204
91	Q203	800-819-00	MOORE INDUSTRIES INC.	Q203
92	Q201	800-810-00	MOORE INDUSTRIES INC.	Q201
93	Q202	800-880-00	MOORE INDUSTRIES INC.	Q202
94	Q204	800-819-00	MOORE INDUSTRIES INC.	Q204
95	C201	.01/100V	MOORE INDUSTRIES INC.	C201
96	R210	22K	MOORE INDUSTRIES INC.	R210
97	R208	1K	MOORE INDUSTRIES INC.	R208
98	R209	10K	MOORE INDUSTRIES INC.	R209
99	R213	2.2K	MOORE INDUSTRIES INC.	R213
100	C201	.01/100V	MOORE INDUSTRIES INC.	C201

6 > INDICATES TEST POINTS; FILLED END IS POINTER
 SEE SEC. 5 OF "MANUAL, MAINTENANCE"
 5 ⊕ INDICATES CIRCUIT COMMON (GROUND)
 4 ⊔ INDICATES INTERCONNECT PIN
 3 [] METAL FILM RESISTORS, 1/4 W, 1%
 2 RESISTORS ARE CARB. COMP., 1/4 W, 1%
 1 RESISTANCE IN OHMS, CAPACITANCE IN MICROFARADS
 NOTES:

SCHEMATIC
 POWER SUPPLY
 REGULATOR
 (ALM PC2)
 DO NOT SCALE DRAWING
 SCALE 1:1
 DRAWING NO. 400

MOORE
 INDUSTRIES INC.
 VAN NUYS - CALIF.
 158-408-00A

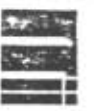

MOORE INDUSTRIES
 16650 Schoenborn Street
 Sepulveda, California 91343

DO NOT SCALE DRAWING	
TOLERANCES UNLESS NOTED	12/1/78
X .XX	1/4" = 1"
.XXX	1/8" = 1"
ANGLES ±30°	1/2" = 1"
SCALE	1/4" = 1"

STANDARD
 ALM
 PC-2

DRAWING NUMBER	158-508-00	REVISION	A
CATEGORY	P.C. ASSEMBLY	DATE	1/27/79
DESIGNED BY	INITIAL RELEASE	BY	JK
APPROVED BY		APPROVAL	

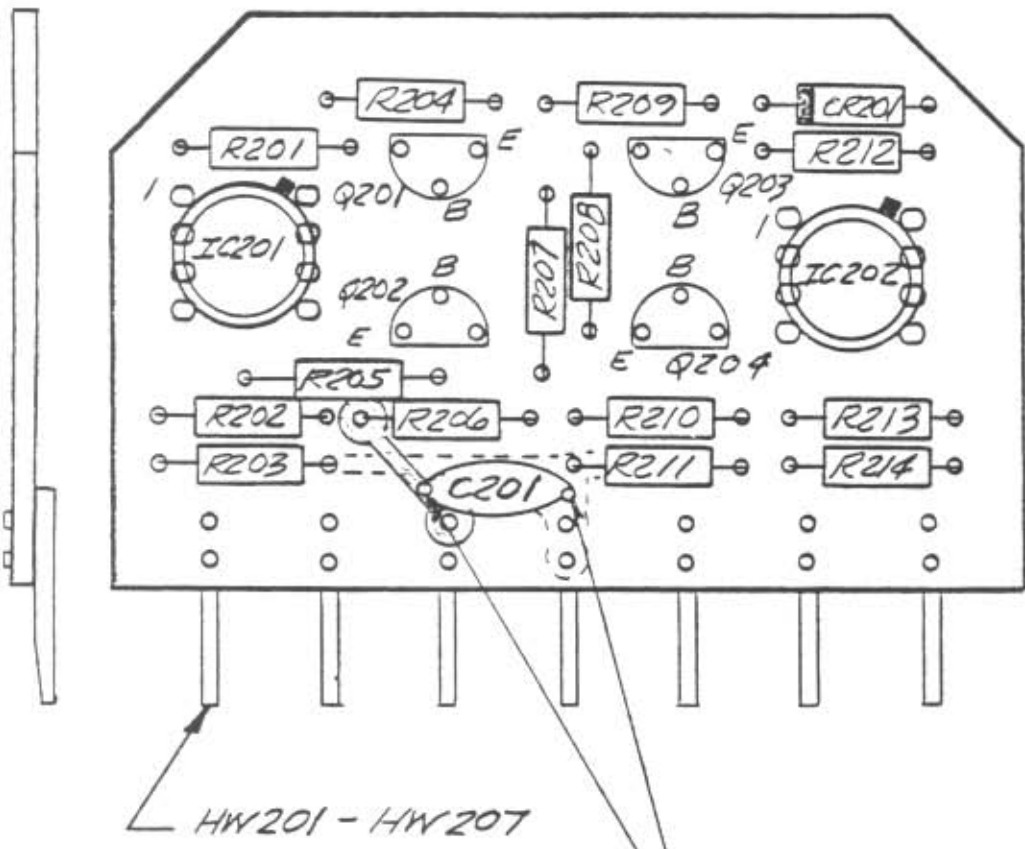

HW201 - HW207

DRILL (2) .031 HOLES

1. SOLDER ALL LEADS TO P.C. BOARD.
 NOTES:

RETURN PROCEDURES

To return equipment to Moore Industries for repair, follow these four steps:

1. Call Moore Industries and request a Returned Material Authorization (RMA) number.

Warranty Repair –

If you are unsure if your unit is still under warranty, we can use the unit's serial number to verify the warranty status for you over the phone. Be sure to include the RMA number on all documentation.

Non-Warranty Repair –

If your unit is out of warranty, be prepared to give us a Purchase Order number when you call. In most cases, we will be able to quote you the repair costs at that time. The repair price you are quoted will be a "Not To Exceed" price, which means that the actual repair costs may be less than the quote. Be sure to include the RMA number on all documentation.

2. Provide us with the following documentation:
 - a) A note listing the symptoms that indicate the unit needs repair
 - b) Complete shipping information for return of the equipment after repair
 - c) The name and phone number of the person to contact if questions arise at the factory
3. Use sufficient packing material and carefully pack the equipment in a sturdy shipping container.
4. Ship the equipment to the Moore Industries location nearest you.

The returned equipment will be inspected and tested at the factory. A Moore Industries representative will contact the person designated on your documentation if more information is needed. The repaired equipment, or its replacement, will be returned to you in accordance with the shipping instructions furnished in your documentation.

WARRANTY DISCLAIMER

THE COMPANY MAKES NO EXPRESS, IMPLIED OR STATUTORY WARRANTIES (INCLUDING ANY WARRANTY OF MERCHANTABILITY OR OF FITNESS FOR A PARTICULAR PURPOSE) WITH RESPECT TO ANY GOODS OR SERVICES SOLD BY THE COMPANY. THE COMPANY DISCLAIMS ALL WARRANTIES ARISING FROM ANY COURSE OF DEALING OR TRADE USAGE, AND ANY BUYER OF GOODS OR SERVICES FROM THE COMPANY ACKNOWLEDGES THAT THERE ARE NO WARRANTIES IMPLIED BY CUSTOM OR USAGE IN THE TRADE OF THE BUYER AND OF THE COMPANY, AND THAT ANY PRIOR DEALINGS OF THE BUYER WITH THE COMPANY DO NOT IMPLY THAT THE COMPANY WARRANTS THE GOODS OR SERVICES IN ANY WAY.

ANY BUYER OF GOODS OR SERVICES FROM THE COMPANY AGREES WITH THE COMPANY THAT THE SOLE AND EXCLUSIVE REMEDIES FOR BREACH OF ANY WARRANTY CONCERNING THE GOODS OR SERVICES SHALL BE FOR THE COMPANY, AT ITS OPTION, TO REPAIR OR REPLACE THE GOODS OR SERVICES OR REFUND THE PURCHASE PRICE. THE COMPANY SHALL IN NO EVENT BE LIABLE FOR ANY CONSEQUENTIAL OR INCIDENTAL DAMAGES EVEN IF THE COMPANY FAILS IN ANY ATTEMPT TO REMEDY DEFECTS IN THE GOODS OR SERVICES, BUT IN SUCH CASE THE BUYER SHALL BE ENTITLED TO NO MORE THAN A REFUND OF ALL MONIES PAID TO THE COMPANY BY THE BUYER FOR PURCHASE OF THE GOODS OR SERVICES.

ANY CAUSE OF ACTION FOR BREACH OF ANY WARRANTY BY THE COMPANY SHALL BE BARRED UNLESS THE COMPANY RECEIVES FROM THE BUYER A WRITTEN NOTICE OF THE ALLEGED DEFECT OR BREACH WITHIN TEN DAYS FROM THE EARLIEST DATE ON WHICH THE BUYER COULD REASONABLY HAVE DISCOVERED THE ALLEGED DEFECT OR BREACH, AND NO ACTION FOR THE BREACH OF ANY WARRANTY SHALL BE COMMENCED BY THE BUYER ANY LATER THAN TWELVE MONTHS FROM THE EARLIEST DATE ON WHICH THE BUYER COULD REASONABLY HAVE DISCOVERED THE ALLEGED DEFECT OR BREACH.

RETURN POLICY

For a period of thirty-six (36) months from the date of shipment, and under normal conditions of use and service, Moore Industries ("The Company") will at its option replace, repair or refund the purchase price for any of its manufactured products found, upon return to the Company (transportation charges prepaid and otherwise in accordance with the return procedures established by The Company), to be defective in material or workmanship. This policy extends to the original Buyer only and not to Buyer's customers or the users of Buyer's products, unless Buyer is an engineering contractor in which case the policy shall extend to Buyer's immediate customer only. This policy shall not apply if the product has been subject to alteration, misuse, accident, neglect or improper application, installation, or operation. THE COMPANY SHALL IN NO EVENT BE LIABLE FOR ANY INCIDENTAL OR CONSEQUENTIAL DAMAGES.



WORLDWIDE • www.miinet.com

United States • info@miinet.com Tel: (818) 894-7111 • FAX: (818) 891-2816	Belgium • info@mooreind.be Tel: 03/448.10.18 • FAX: 03/440.17.97	China • sales@mooreind.sh.cn Tel: 86-21-62491499 • FAX: 86-21-62490635
Australia • sales@mooreind.com.au Tel: (02) 8536-7200 • FAX: (02) 9525-7296	The Netherlands • sales@mooreind.nl Tel: (0)344-617971 • FAX: (0)344-615920	United Kingdom • sales@mooreind.com Tel: 01293 514488 • FAX: 01293 536852